

# IWTS-28 SUB

High Performance  
In-Wall Subwoofer



**Atlantic**  
TECHNOLOGY

# Instruction Manual

## Table of Contents

- 2 Model IWTS-28 SUB**
- 2 Important Considerations Before Installation**
  - 2 Recommended Wire Sizes
  - 3 Location Considerations
- 4 Connecting the IWTS-28 SUB to Your System**
  - 4 To Connect as a Powered Subwoofer
  - 4 To Connect as a Passive Bass Module
- 5 Mounting the IWTS-28 SUB**
- 5 Installation of the IWTS-28 SUB in New Construction**
- 5 Installation of the IWTS-28 SUB in Existing Construction**
  - 5 Removing and Installing the Grille
  - 5 Treating the Wall Cavity
  - 5 Cutting the Opening
  - 6 Installing the Mounting Frame
  - 6 Painting the Speaker Assembly
  - 6 Speaker Connection and Assembly
  - 6 Installing the Speaker Enclosure Into the Frame
- 7 Front Panel Controls**
  - 7 Low-Pass Control
  - 7 IR Knockout
- 7 Specifications**

# Model IWTS-28 SUB

## In-Wall Subwoofer

Thank you for purchasing Atlantic Technology products. Our speaker systems have been designed to deliver exceptional sound and value. We hope you like what you hear from them, and are happy with your decision to buy them.

Please take a few moments to read these instructions. They're intended not only to tell you how to mount the speakers, but how to get the best performance from them.

## Important Considerations Before Installation

### Recommended Wire Sizes

The longer the wire run, the heavier the wire should be. Use the following recommendations as a guide for your installation. And if you're in doubt, remember that it never hurts to get the next heavier grade of wire. Also note that lower gauge numbers equal heavier wire sizes.

### Wire Run Wire Gauge:

- <15 ft. 16 ga.
- 15 to 30 ft. 14 ga.
- >30 to 50 ft. 12 ga.

## For Future Reference

Record your serial numbers and date of purchase here:

Model Number \_\_\_\_\_

Serial Number \_\_\_\_\_

Date of Purchase \_\_\_\_\_

The serial number is found on the back panel.

Copyright © 2008 Atlantic Technology International.

Specifications are those in effect at the time of printing. Atlantic Technology reserves the right to change specifications or designs at any time without notice.

### Location Considerations

Choosing the location for the subwoofer is a very important consideration. Since the IWTS-28 SUB can't easily be moved once it's installed (!), very careful consideration should be given to its placement. In general, the cleanest and most articulate delivery of bass energy into the room occurs when the subwoofer is placed asymmetrically with respect to the room's dimensions. (see fig. 1). Such placement generally results in the best overall balance of bass impact vs. 'one-note boom.'

Figure 1 – Asymmetrical Placement

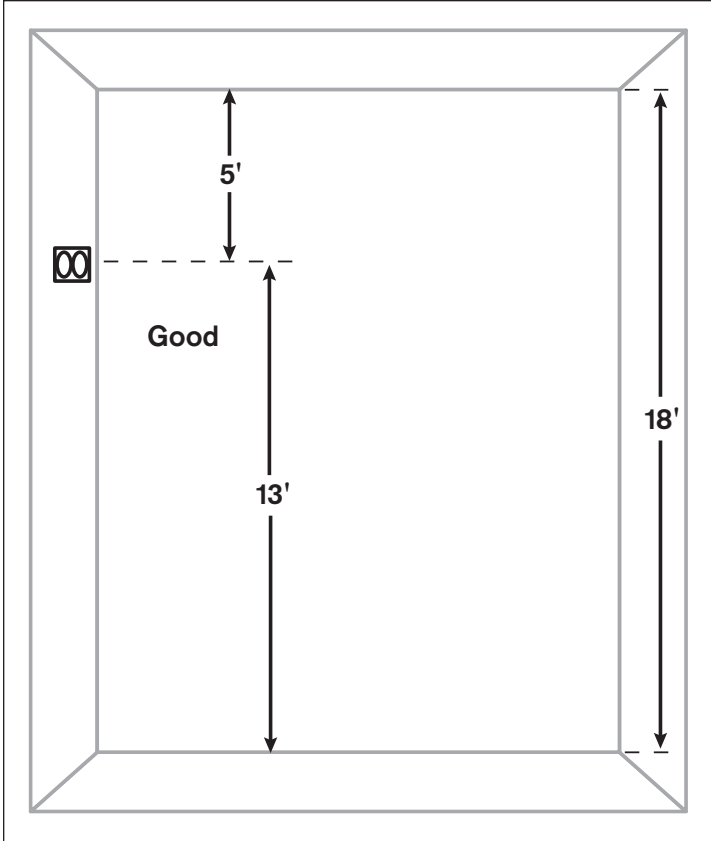

If you are using two 28 SUB modules, follow the same advice: locate them asymmetrically within the room (i.e. one near a corner, one towards the middle of a wall) to smooth out the bass and minimize random standing wave patterns. (see fig. 2)

Figure 2 – Dual Sub Placement

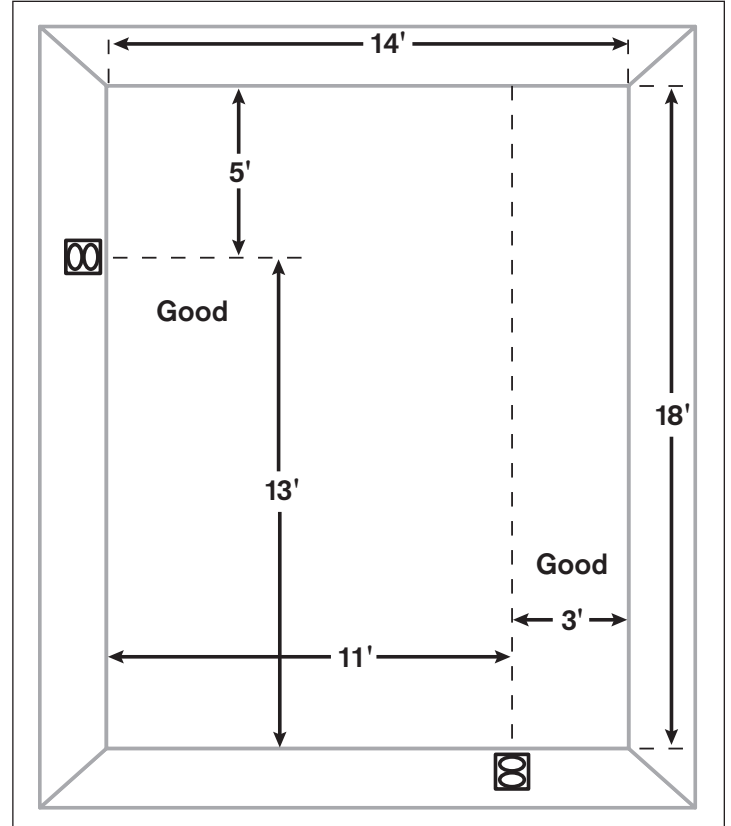

## Connecting the IWTS-28 SUB to Your System

The IWTS-28 SUB may be used as a passive bass module to reinforce the bass from the left/right front speakers in your system, or it may be powered by an external amplifier (such as Atlantic's SA-180 mono bloc amplifier).

### To Connect as a Powered Subwoofer:

Leaving the jumpers in place, connect the speaker wires from the SA-180 to one black terminal and one red terminal on the 28 SUB. Make sure the 28 SUB's front-panel low-pass switch is in the off position (see fig. 3).

Figure 3 – IWTS-28 SUB jumpers

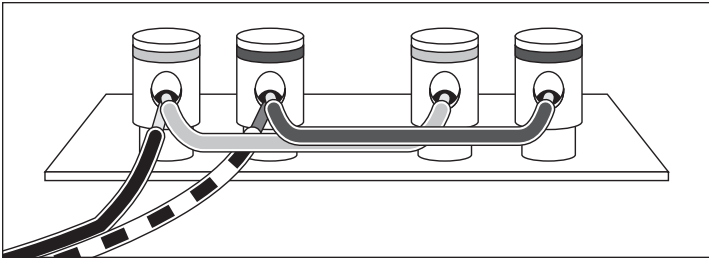
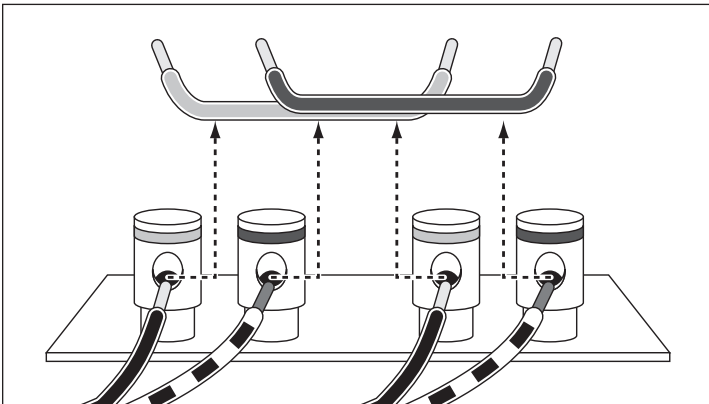

Figure 4 – Removing the IWTS-28 SUB jumpers



### To Connect as a Passive Bass Module:

Remove the jumpers from the 28 SUB's terminals (see fig. 4). Run speaker wires from the receiver's front left speaker terminals to one set of terminals on the 28 SUB. Run another set to the other set of terminals on the 28 SUB. (see fig. 5) It does not matter which woofer on the 28 SUB is considered 'right' or 'left,' since bass is generally recorded in mono, and is non-directional anyway. Be careful to observe consistent polarity between the two woofers, and between the woofers and front L/R speakers. All reds and blacks should be consistent.

Be sure to switch the 28 SUB's front panel low-pass switch to "on." This will filter out any signal above around 200 Hz from reaching the 28 SUB module, and ensures that only the non-directional lower frequencies are being fed to the SUB, thus preserving your system's front-channel sonic imaging.

**IMPORTANT NOTE:** Each individual woofer in the 28 SUB is 8 ohms; when connecting them in parallel with your front L/R speakers (as you do when using the 28 SUB passively), the front L/R speakers need to also be 8 ohms minimum, so that their combined paralleled impedance does not fall below 4 ohms. Consult your receiver's owner's manual for more information on its impedance drive capability.

Figure 5 – Connecting as a Passive Bass Module

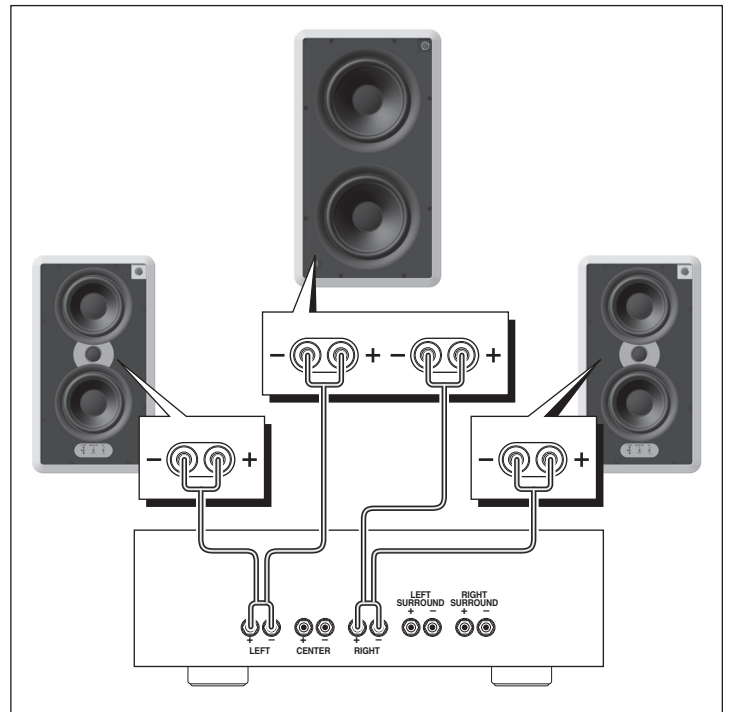

## Mounting the IWTS-28 SUB

**NOTE:** We always recommend a professional be involved in the installation of IWTS speakers, if at all possible.

You will need the **Grille/Frame assembly GFR-626, sold separately.**

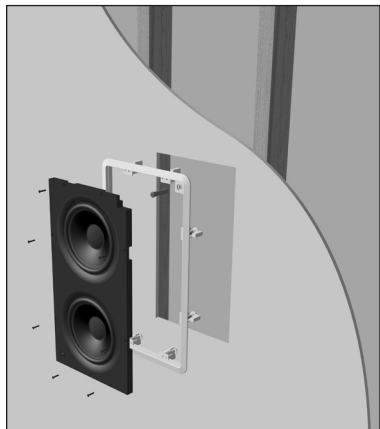

The GFR-626 can be easily mounted in most any standard wall material, from ½ to 1½ inches thick. Its rotating wall clamps (sometimes called “dog legs”) firmly fix it to the wall surface after the proper cutout has been made. Here are some important precautions to take before mounting:

Keep the sides of the actual mounting hole at least 1½ inches away from beams or studs to

ensure that the clamps have adequate room to rotate. A stud or other obstruction that’s too close will stop them from properly doing their job.

## Installation of the IWTS-28 SUB in New Construction

Atlantic Technology offers an optional Rough-in Frame Kit to ease installation in new construction. Instructions for its use are included with this kit. Ask your Atlantic dealer for more details. The kit’s model number is IN-NC-626.

## Installation of the IWTS-28 SUB in Existing Construction

### Removing and Installing the Grille

Remove the grille from the speaker using an awl or the point of a drywall screw in a grille opening near one of the grille corners. Slowly pry the grille out, being careful not to damage the speaker’s frame or its finish.

To re-install the grille later, press it carefully into the appropriate opening in the frame assembly. Since it’s designed to fit snugly, please take your time and use care when installing the grille.

## Treating the Wall Cavity

The IWTS-28 SUB does not require a back box. It is designed to work properly in a standard full-sized wall cavity. This is commonly called an “infinite baffle” installation. However even though there is no back box, you should exercise good acoustic/mechanical common sense, and prepare the wall cavity as follows:

- Make sure there are no extraneous house electrical wires, plumbing, junction boxes, or other items that could rattle or vibrate from the 28 SUB’s output. A subwoofer moves a considerable amount of air, and if something *can* rattle, it probably *will* rattle. It’s much, much easier to ‘button everything down’ securely before you install the sub then it is to try to hunt down an intrusive buzz or rattle later on.
- Seal all the stud-to-drywall seams with a flexible silicone construction caulk. This will help keep the drywall itself from flexing and rattling against the studs, and it helps form a more airtight “enclosure” for the 28 SUB.
- Fill the wall cavity loosely with acoustic speaker stuffing (“polyfill”). It is not necessary to pack the stuffing in extremely tight; in fact, that will reduce the bass output.

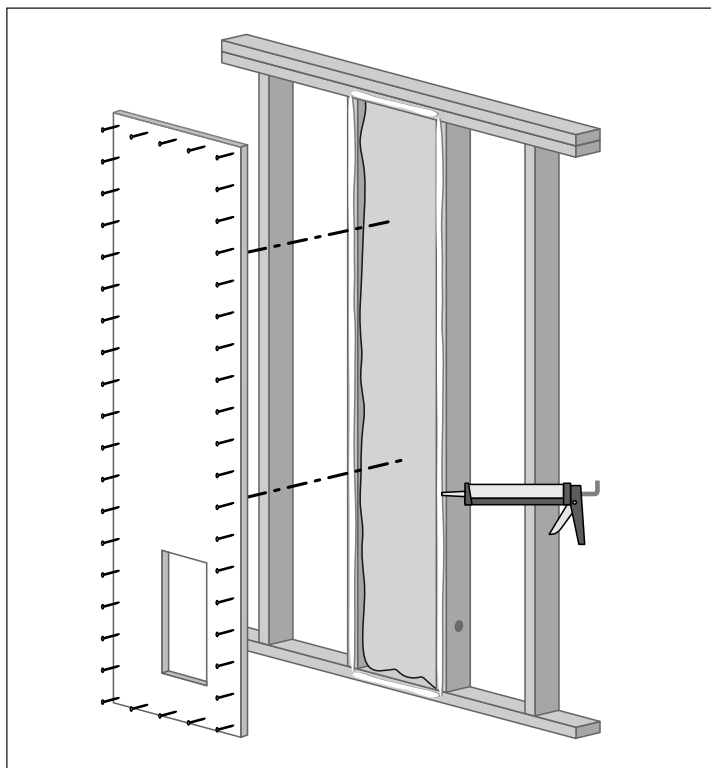

- If this is new construction, we strongly recommend using 5/8” or 3/4” sheetrock. It’s heavier and more expensive than ½” material, but it’s far, far superior in terms of acoustic/mechanical integrity and rigidity. We also strongly recommend that the sheetrock be screwed to the studs every 6 inches or so, instead of the more common practice of nailing it every 12-18”. Use screws for at least a full stud bay on either side of where the 28 SUB will be mounted.
- If you drill a hole in the stud to snake the speaker wires through, be certain to seal that hole with silicone caulk.

## Cutting the Opening

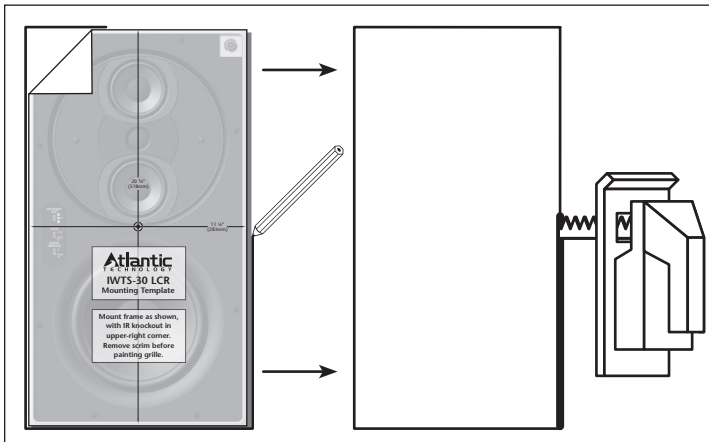

After determining the best location for the speaker as outlined above, use the template included with the GFR-626 to cut the proper size hole.

**WARNING: EXERCISE** extreme care before making any wall cuts to ensure that you will not cut through any wires, pipes, or other items that may be in the wall. You may sometimes, but not always, be able to determine the approximate location of wires and pipes by looking at the locations of nearby outlets and plumbing. But their location or absence is never an assurance that there is not something within the wall cavity.

## Installing the Mounting Frame



The damping mechanism allows the wall material to range from  $\frac{1}{2}$  to  $1\frac{1}{2}$  inches (13 to 38 mm) in thickness. There must be a minimum depth behind the wall face of  $3\text{--}5\frac{5}{8}$ " (92 mm). As noted above, be sure to keep the edges of the cutout at least  $1\frac{1}{2}$  inch (38mm) away from any stud or obstruction, as the rotating clamps will not operate properly if you don't. The speaker baffle is designed to mount into the white frame, after the frame is mounted into the wall.

Insert the frame into the cutout and using a level or square carefully align it so it is level. Tighten the mounting screws, which will cause the attached clamps to rotate and position themselves properly behind the wall.

Continue to tighten until the frame is snug in the wall. You want the bezel to conform to the wallboard, and the frame not to rattle from the speaker's vibration, **but be very careful not to overtighten the screws.**

## Painting the Speaker Assembly

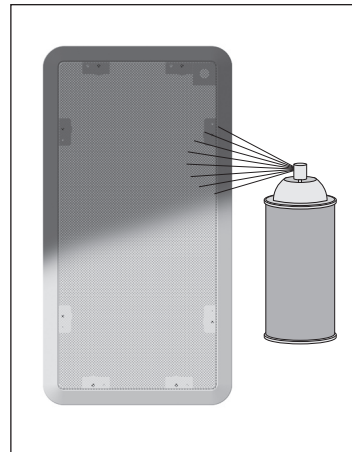

The white plastic frame and the metal grille may be left as is, or painted to match your décor. You can paint the frame before or after it is installed in the wall. Spray painting (using slightly thinned paint) is the best method to use for painting the grille. Be sure to remove the scrim cloth before painting the grille. After painting the grille, use air pressure to "blow out" any grille holes that are filled in with paint. Then re-apply the scrim cloth.

## Speaker Connection and Assembly

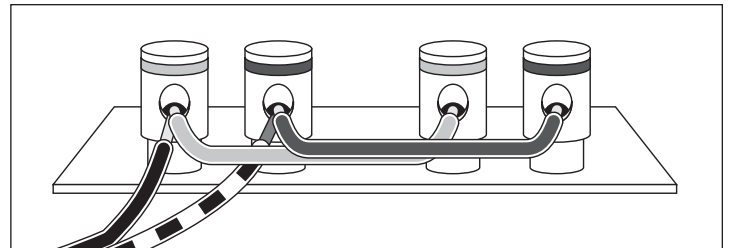

Strip about  $\frac{1}{2}$ " (13 mm) of insulation from the connecting wires. Connect them to the appropriate push terminal, being careful to observe polarity (positive to the red terminal, negative to the black terminal).

## Installing the Speaker Assembly into the Frame

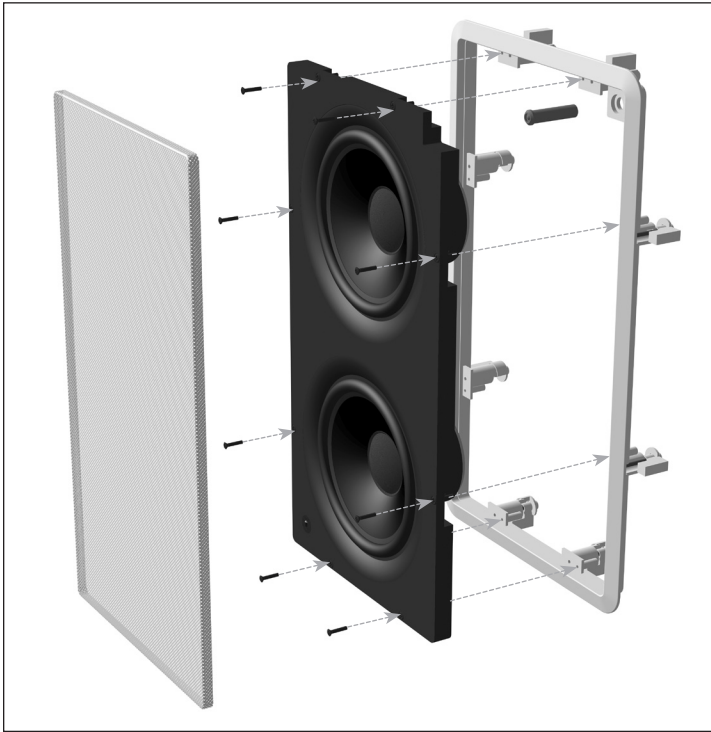

Once the frame is mounted in the wall, the speaker assembly simply fits into the frame as shown.

Use the included screws to attach the enclosure to the mounting frame.

## Front Panel Controls

### Low-Pass Control



The IWTS-28 SUB has a front-mounted control that selects or bypasses the speaker's built-in low-pass crossover. Leave this in the off position when using the 28 SUB with an outboard amplifier and your receiver's low-pass crossover.

### IR Knockout



There's an IR "knockout" plug in the upper right corner of the baffle. If you are using a multi-room control system, you can install a standard IR receiver in the knockout hole.

Should you have any questions or problems please feel free to contact us at 781-762-6300 or through our web site, [www.atlantictechnology.com](http://www.atlantictechnology.com).

## Specifications

### IWTS-28 SUB

<b>Overall Dimensions</b> (W x H x D)	12 <sup>5</sup> / <sub>16</sub> x 21 <sup>1</sup> / <sub>8</sub> x 3 <sup>7</sup> / <sub>8</sub> " (312 x 547 x 100mm)
<b>Cut-out Dimensions</b> (W x H)	11 <sup>1</sup> / <sub>8</sub> x 20 <sup>3</sup> / <sub>8</sub> " (283 x 518mm)
<b>Drivers/Design</b>	Dual 8" (203mm) long-throw, 40mm voice coils
<b>Frequency Response</b>	38-200 Hz +/- 3dB, passive response
<b>Recommended Amplifier Power</b>	30-200 Watts RMS
<b>Low-pass Filter Frequency</b>	200 Hz
<b>Sensitivity</b>	89dB
<b>Impedance</b>	Each individual woofer 8 ohm; paralleled 4 ohms
<b>Required Grille/frame assembly</b>	GFR-626

*Specifications are those in effect at the time of printing. Atlantic Technology reserves the right to change specifications or appearance at any time without notice.*



343 Vanderbilt Avenue Norwood, MA 02062 (781) 762-6300 [www.atlanticttechnology.com](http://www.atlanticttechnology.com)